

### V1000 - ACCESS CONTROLLER

(REQUIRED)  
SEE NOTE 6

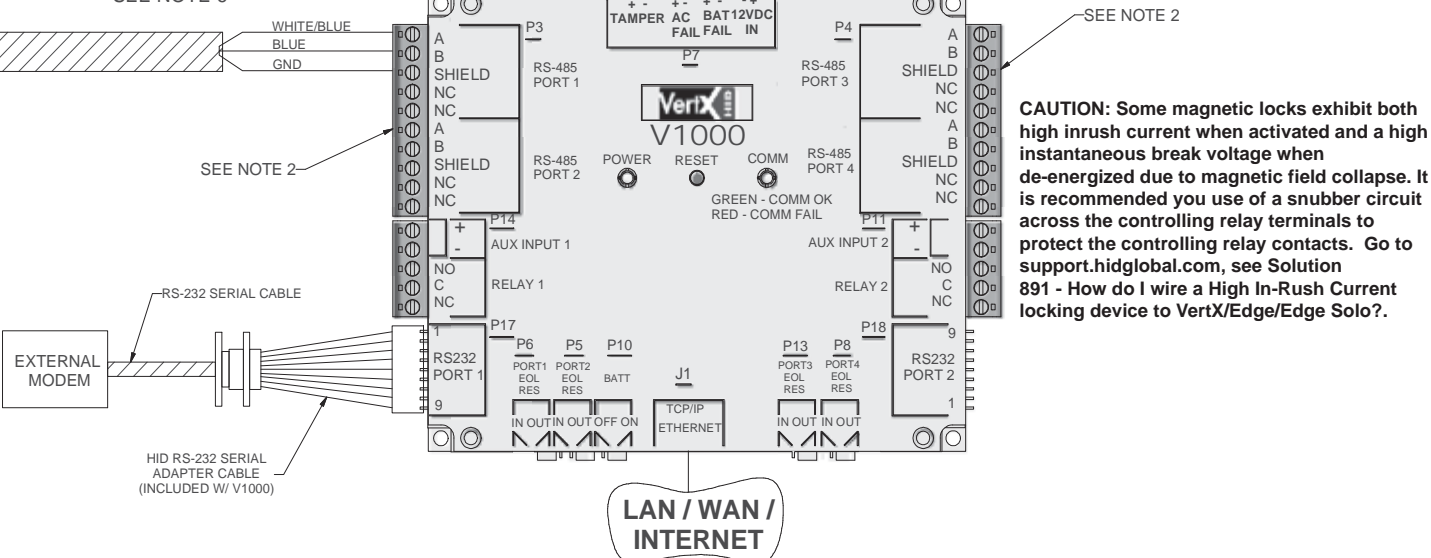

SEE NOTE 2

**CAUTION: Some magnetic locks exhibit both high inrush current when activated and a high instantaneous break voltage when de-energized due to magnetic field collapse. It is recommended you use of a snubber circuit across the controlling relay terminals to protect the controlling relay contacts. Go to support.hidglobal.com, see Solution 891 - How do I wire a High In-Rush Current locking device to VertX/Edge/Edge Solo?.**

### V200 - INPUT MONITOR INTERFACE

(OPTIONAL - ADDITIONAL MONITORING)

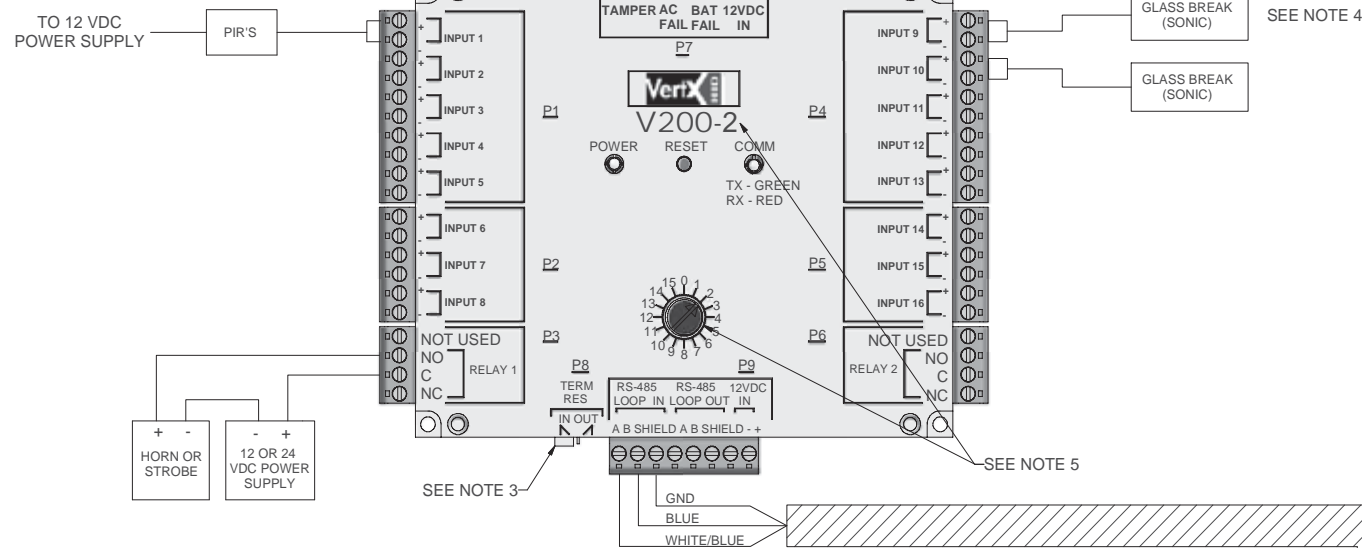

### V100 - DOOR/READER INTERFACE

CARD IN / FREE OUT

(MOST COMMON OPTION)

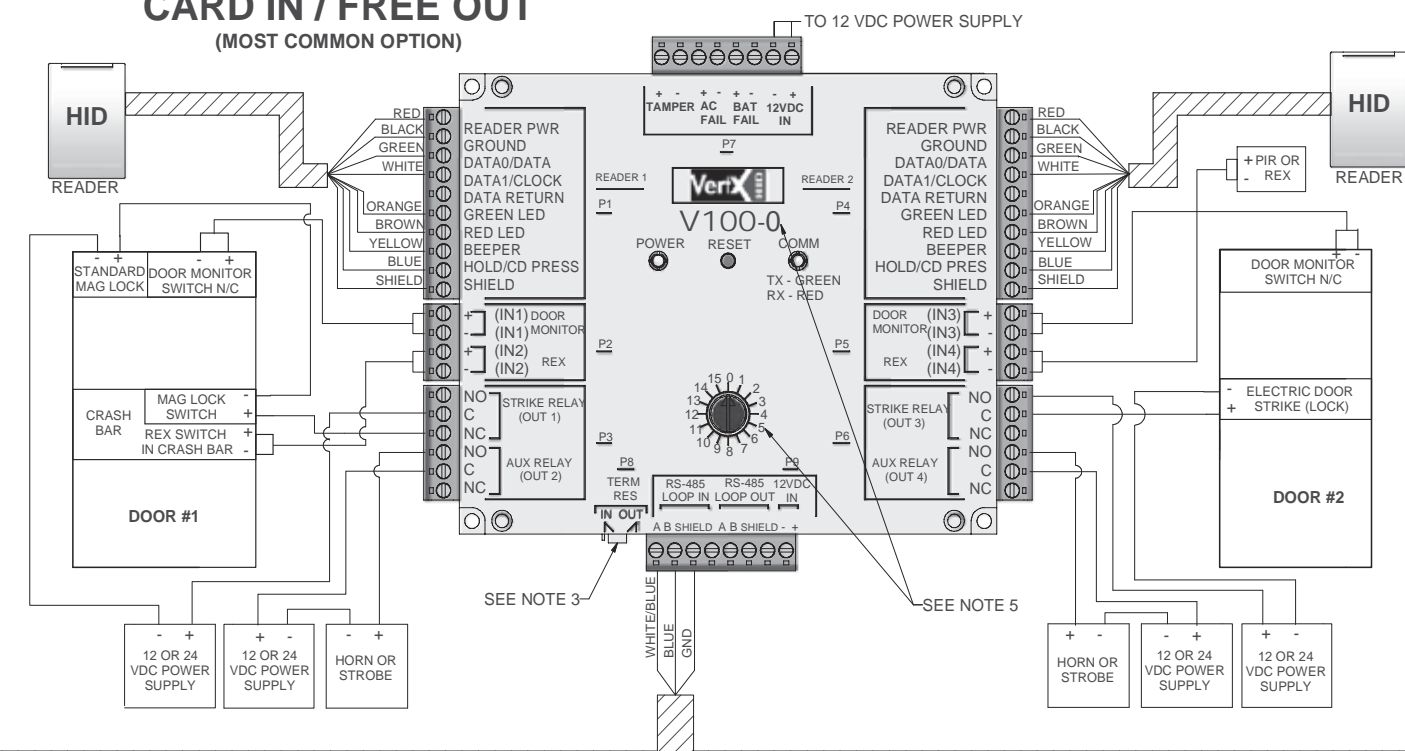

### V100 - DOOR/READER INTERFACE

CARD IN / CARD OUT

(LESS COMMON OPTION)

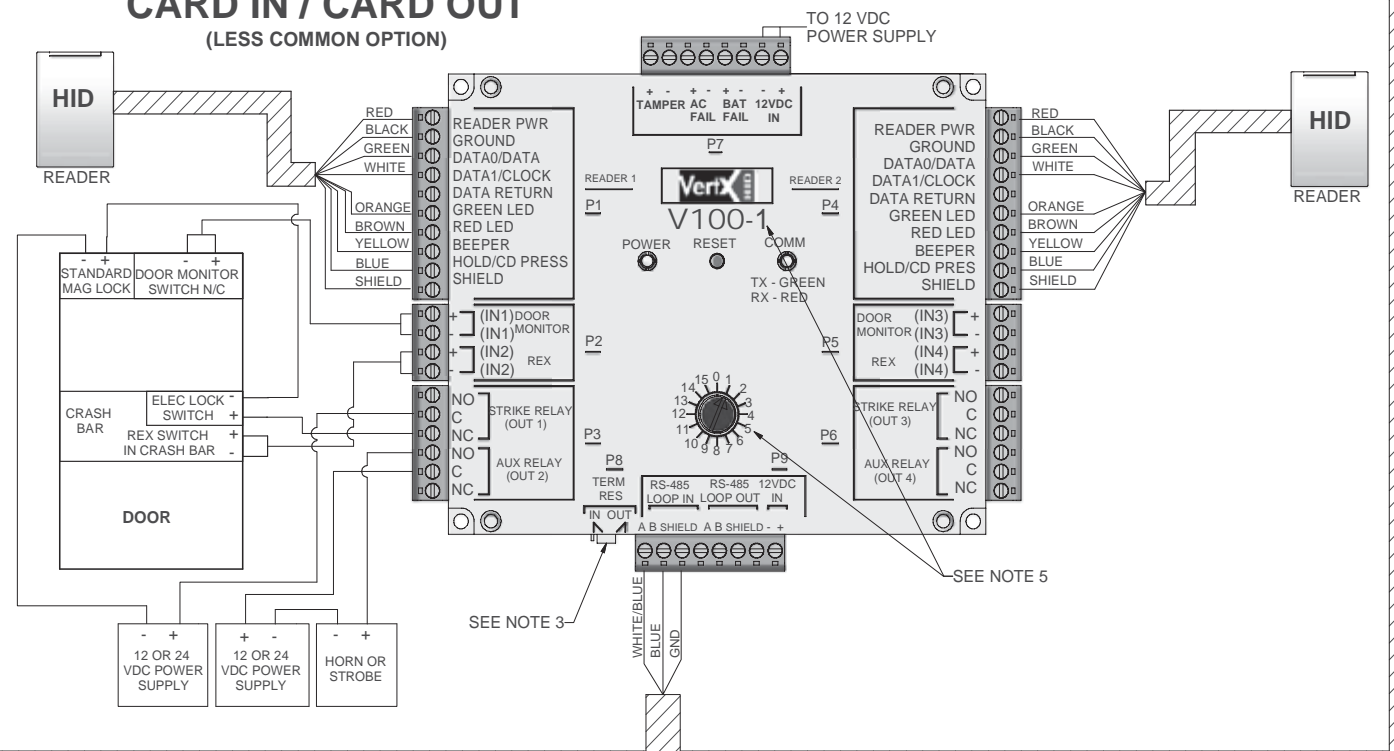

#### NOTES, UNLESS OTHERWISE SPECIFIED:

1. THIS VERTX INSTALLATION WIRING DIAGRAM IS INTENDED AS AN EXAMPLE ONLY, AND SHOULD NOT BE INTERPRETED AS AN HID CORPORATION RECOMMENDATION.
2. THE V1000 PHYSICAL RS-485 PORT 1 AND 2 RESIDE ON LOGICAL BUS 1 (P3), WHILE PORT 3 AND 4 RESIDE ON RS-485 LOGICAL BUS 2 (P4).
3. THE TERMINATION JUMPER SHOULD BE IN THE "OUT" POSITION FOR ALL V100 SERIES PANELS EXCEPT FOR THE LAST V100 SERIES PANEL ON THE RS-485 RUN. THE LAST V100 SERIES PANEL MUST HAVE THE TERMINATION JUMPER IN THE "IN" POSITION.
4. THE DEFAULT SETTINGS FOR ALL VERTX INPUT DEVICES ARE NORMALLY OPEN (N/O), EXCEPT DOOR MONITOR INPUT WHICH IS NORMALLY CLOSED (N/C).
5. THIS NUMBER INDICATES THE INTERFACE ADDRESS OF THE VertX UNIT. (DASH NUMBER NOT PRINTED ON ACTUAL COVER). DO NOT DUPLICATE ADDRESSES ON THE SAME BUS.
6. SUPPORTS UP TO (ANY COMBINATION OF) 32 INTERFACE PANELS. SEE THE QUICK INSTALL GUIDE FOR DETAILS.

REVISION HISTORY			
REV	ECO #	DESCRIPTION	
C.1	ITG03930	ADDED CAUTION	
C	ITG01697	CORRECT ERRS	

THIS DOCUMENT CONTAINS PROPRIETARY INFORMATION. IT MAY NOT BE DISCLOSED TO OTHERS OR USED FOR MANUFACTURING PURPOSES WITHOUT PERMISSION FROM HID CORPORATION.

FIND NO	CAGE NO	QTY REQD	PART OR IDENTIFYING NO	NOMENCLATURE OR DESCRIPTION
EXCEPT AS NOTED DIMENSIONS ARE IN INCHES PER ANSI Y14.5M .XX .XXX ANGLES +/- .01 +/- .005 +/- 1				DO NOT SCALE DRAWING APPROVALS DATE DWN LDixon 011311
MATERIAL				CHG
FINISH				APVD
HID IRVINE, CALIFORNIA				DWG TITLE
VertX INSTALL WIRING DIAGRAM EXAMPLE				SIZE B CAGE CODE 6080-905 DWG NO 6080-905 REV C.1
SCALE: N/A				SHEET: 1 of 1