

□ 3110-5840 Insert Reader, White  
 □ 3110-5841 Insert Reader, Black  
**Specifications**

**INPUT:**  
 Magnetic Stripe Cards, high or low coercivity, EMPI I, EMPI II or ANSI format, up to 14 characters.

**CARD SIZE:**  
 CR-80, 2.125" x 3.375" x .030", Track 1, 2, and 3

**OUTPUT:**  
 Standard Wiegand 5-wire format with optional second LED control line. Optional "Clock and Data" format.

**DISTANCE:**  
 200 feet with #22 AWG wire  
 500 feet with #18 AWG wire

**TEMPERATURE RANGE:**  
 -35 to +66 degrees Celsius (-31 to 150 degrees Fahrenheit).

**POWER:**  
 35 mA at +4.75 VDC to +5.5 VDC

**READ SPEED:**  
 5 to 30 IPS on withdrawal

**DIMENSIONS:**  
 Reader; 4.70" H x 3.00" W x 1.54" D.

**LED:**  
 Two Colors - Red and Green; Optional Amber

**Returned Material**

Before returning ANY product, you must call the Customer Service Department (303) 302-2400, to obtain a Return Material Authorization (RMA) number. Equipment that fails during normal use within the warranty period (see warranty information) will be repaired or replaced at the discretion of Dorado by Hid. Equipment that fails after the warranty period has expired from external sources (such as lightning or abuse) will be repaired at Dorado by Hid's current labor rate after a repair estimate has been provided. Following agreement by the client as evidence by Purchase Order or Credit Card submitted.

**Warranty Information**

Dorado by HID warrants to the original purchaser That card readers are free from defects in material and, workmanship under normal use and service for 27 months, from date of original invoice, (control boards only). Normal wear and tear, including magnetic head wear, and damage caused Force Majeure, is excluded from this warranty. Unless otherwise agreed in writing by Dorado by HID, the buyer shall be responsible to assure the proper installation environment is provided, and Dorado by HID assumes no responsibility for malfunctions or damage due to improper installation of products. Dorado by HID's obligation under this warranty shall be limited to the repair or replacement of any returned product provided that the claim is presented within the time specified above. This warranty is in lieu of all other warranties express or implied, including the warranties of merchantability, or fitness for any particular use. In no event shall Dorado by HID be liable for any breach of warranty in an amount exceeding the net selling price of any defective products.

**FCC Notice**

Federal Communications Commission  
 Radio Frequency Interference Statement  
**Warning:** This equipment complies with the limits for a Class A computing device in accordance with the specifications in Subpart J of Part 15 of FCC rules. These Specifications are designed to minimize radio frequency interference in a residential installation; however there is no guarantee that radio or television interference will not occur in any particular installation. If this equipment does cause interference to radio or television reception, which can be determined by turning the equipment off and on when the radio or television is on, the user is encouraged to try to correct the interference by one or more of the following measures:

- Reorient the radio or television-receiving antenna.
- Relocate the equipment.
- Move the equipment away from the receiver.
- Plug the equipment into a different outlet so that the equipment and receiver are on different branch outlets.

If necessary, the user should consult the dealer or an experienced radio or television technician for additional suggestions. The user may find the following booklet prepared by the Federal Communications Commission helpful:

"Interference to home electronic entertainment equipment handbook"  
 This booklet is available from the:  
 U.S. Government Printing Office  
 To order Government publications,  
 Phone toll free: 866-512-1800 (DC area: 202-512-1800),  
 Fax 202-512-2250,  
 Mail orders to:  
 Superintendent of Documents, P.O. Box 371954,  
 Pittsburgh, PA 15250-7954, or  
 Order online from <http://bookstore.gpo.gov>  
 Order stock number: 004-000-00498-1.

To view a parts list for our pass thru readers:  
 Please go to our website@  
[www.hidcorp.com/dorado](http://www.hidcorp.com/dorado), then click on "Downloads"

PN: 2280-3935  
 REV 5  
 (NA3935)  
 ECO# 081302-2

Card Reader kit consist of:

- 1-Reader assembly
- 1-Installation Kit 2270-0580
- 1-Instructions 2280-3935 (NA3935)

**General**

The Model 584 Insertion Card Reader with keypad reads magnetic stripe cards that have been encoded with Dorado by HID's secure EMPI I or EMPI II encrypted card coding format or standard ABA/ANSI/ISO format.

The Model 584 Reader is designed for indoor or outdoor use. The Model 584 Reader has a membrane keypad that will report keystrokes to the host. The 584 Card Reader is normally wall mounted with the card insertion slot facing the floor.

Cards are inserted into the bottom of the reader and read upon withdrawal. The information is transmitted to any host controller that can supply a +5 VDC operating voltage to the reader, and that can accept the standard Wiegand 26-bit or 34-bit format or Clock and Data format.

**Before Installing**

- 1 Reader installation and wiring must conform to applicable local codes, ordinances, and regulations.
- 2 The host controller must supply +5 VDC operating voltage to the reader. The voltage drop as measured across the reader must be within 4.75 to 5.25 VDC.
- 3 The maximum recommended reader distance from the host is:  
 200 feet with #22 AWG 5 or 6-wire cable  
 500 feet with #18 AWG 5 or 6-wire cable  
 Unshielded wire is acceptable. Some host controllers may require tighter standards.
- 4 Reader options are selected by four DIPswitches located on the lower left of the reader circuit board. See Options section.
- 5 If EMPI cards are used, the proper 8-bit or 16-bit "Comparison Number" (similar to a site or facility code) must be entered into memory of the host access controller. These numbers, as well as the "Job Code" number used when reordering EMPI Cards, will be found printed on the label of your EMPI Card carton. If ABA/ANSI/ISO cards are used, program the site code and/or User ID's into the host access controller as appropriate. Request Dorado by HID Application Note 23 for details on coding and reading ABA/ANSI/ISO format cards into 26/34-bit Wiegand data.



9292 Jeronimo Road  
 Irvine, CA 92618-1905  
 Phone : +1 (949) 598-1600  
 Fax : +1 (949) 598-1619

**Mounting**

- 1 The reader is designed to be mounted with the slot facing the floor. The user inserts the card upward into the card insertion slot.
- 2 The reader can be mounted on a standard single-gang handy box, (the preferred method) or on any firm flat surface. The mounting screws should be firmly tightened, but not excessively. Note that the read head assembly screws are purposely loose to allow the head to "float"; no adjustments are necessary. See figure 1.

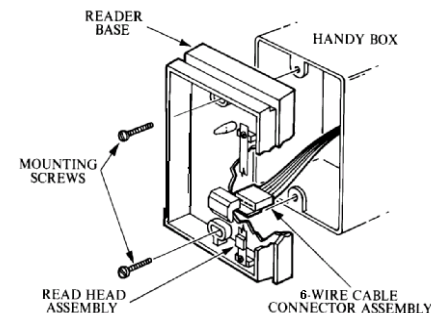

Figure 1

- 3 For outdoor applications, use a suitable weather-proof back box, or handy box, and install the weather seal (provided) on the back of the readers' base by pushing it securely and evenly into the "U" shaped recess. See figure 2.

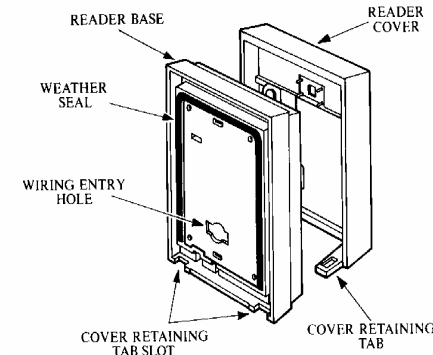

Figure 2

- 4 Recommended reader-mounting height from the floor is "shoulder height" or about 60 inches. A lower height causes significant user inconvenience. Reader height may be lowered to accommodate ADA requirements.

## Installation Steps

### WARNING

To prevent damage to equipment, make all connections with power-off and the connector unplugged from the reader.

- 1 If the reader is to be mounted on a single-gang handy box, pull an appropriate length and gauge of cable between the host and handy box:

200 feet with #22 AWG wire cable  
500 feet with #18 AWG wire cable

Most applications will only require a 5-conductor cable. If the second LED control line is used, a 6-conductor cable is required.

- 2 If the reader is to be mounted on a flat surface rather than a handy box, use the reader base both as a template to establish drill locations for suitable molly fasteners, etc. (not provided), and as a guide to remove sufficient material for wire and connector clearance. Then pull the appropriate wire between the host and reader location as in Step 2.

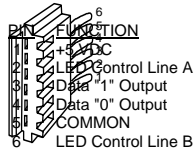

- 3 Connect the wires of the cable connector assembly to the cable end at the reader location. Connections can be crimped or made with twist on wire nuts. Do not plug the connector into the reader at this time.
- 4 Connect the other end of the cable to the host controller being sure to follow the appropriate color code and wire lead functions.
- 5 If not already accomplished, set the appropriate reader DIPswitch options A, B, C, and D (see Options section). Install the neoprene weather seal on back of the reader base (this seal is mandatory for all outdoor installations).
- 6 Verify that the cards to be read are encoded on ISO track 2 (factory default). Request Dorado by HID Application Note 24 if you need information on moving the head to ISO track location 1 or 3.
- 7 Plug the cable connector assembly into the back of the reader (the plug is designed to fit only one way), and mount the reader base to the handy box or other suitable flat surface.
- 8 Apply power to the host controller. If not already accomplished, enter into host memory the appropriate 8-bit or 16-bit "Comparison Number" (if EMPI), card ID numbers, etc. The "Comparison Number" will be found printed on the label of your EMPI Card carton.
- 9 Observe the reader LED; it should flash green four times as a self-test when first powered on. If this is not the case, or it continues with short double flashes, a problem exists, refer to the Diagnostic Tests section.
- 10 Plug the keypad connector into the 8-pin header at the upper left of the reader circuit board. The cable should be installed so that the cable lies flat when the cover is closed.

- 11 Attach the reader cover to the base, and make the appropriate card tests. Observe the LED for proper sequence. If a problem exists refer to the Diagnostic Tests section; otherwise the installation is complete.

## EMPI™ Comparison Number Check

- 1 In Dorado by HID's secure EMPI I or EMPI II encrypted card format, each user organization or location is assigned a unique sequential number called a "Job Code" that is used to administer that card account and to reorder cards.
- 2 The "Job Code" is also used to generate a unique, random, never repeated elsewhere, 16-bit number. For added security, this number and the card ID number is encoded on the EMPI Card in an encrypted format. When the EMPI Card is read, the reader converts this number into the "Comparison Number" (often called a "Site Code").
- 3 If the host controller accepts 34-bit Wiegand data, enter into host memory the full 16-bit "Comparison Number" found on the label of your EMPI Card carton.
- 4 If the host controller accepts 26-bit Wiegand data, enter into host memory the 8-bit "Comparison Number" found on the label of your EMPI Card carton.
- 5 If the host uses other than an 8-bit or 16-bit number, contact the Customer Service department at Dorado by HID. (303) 302-2400.

## Options

Reader options are selected by four DIPswitches located at the lower left of the reader circuit board. The options control the card type accepted (ABA or EMPI) as well as the data output format.

Switch	Options			
A	B	C	D	Function
off	off	off	off	ABA Card with source select
off	off	on	off	Reserved
off	on	off	off	EMPI card to 26-bit Wiegand*
off	on	on	off	EMPI card to 34-bit Wiegand
on	off	off	off	ABA card, all bits clock and data
on	off	on	off	ABA card, all bits Wiegand
on	on	off	off	ANSI/10 card to 26-bit Wiegand
◆	◆	◆	◆	
on	on	on	off	ANSI/10 card to 34-bit Wiegand
◆	◆	◆	◆	

### NOTE:

Option D is not used and should be set to off.

- \* Factory default
- ◆ Request Dorado by HID Application Note 22 for information on data formats from EMPI cards.
- ◆◆ Request Dorado by HID Application Note 23 for details on coding cards for Wiegand format data output.

## Keypad Data

The model 584 keypad sends data keystroke-by-keystroke to the host controller in an 8-bit (per keystroke), data format. See Dorado by HID Application Note 20 for details.

### Reader Cover

#### Attaching and Releasing

The Model 584 reader is shipped from the factory with the reader cover attached to its base.

**CAUTION**  
Before touching any internal reader parts, touch a grounded surface to discharge static electricity from your body.

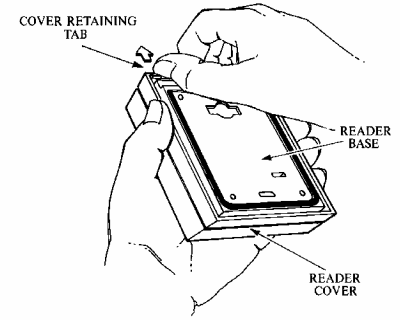

Figure 3

#### To open the reader before mounting:

- 1 Hold the reader in the palm of your hand with the base facing up, and with the card insertion slot pointing away from you, as shown in figure 3.
- 2 With the reader placed as shown, push the cover-retaining tab forward (about 1/16") using your thumbnail until that side "pops" free.
- 3 Place reader in opposite hand, and in a similar manner repeat the previous step to release opposite retaining tab.
- 4 Lift the base at the 'tab' end approximately 1/2", and while holding the cover steady in the palm of your hand, move the base forward (away from you) to separate the base from the cover.

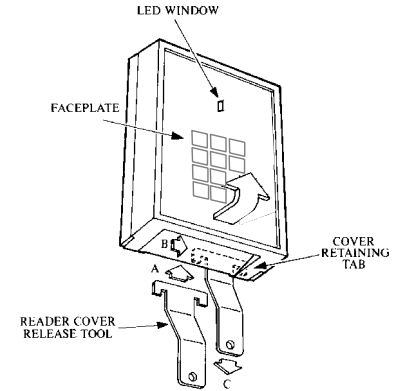

Figure 4

#### To attach reader cover:

To attach the reader cover, place the "ridge" on the inside top of the cover into the corresponding "channel" on the reader base, and then push the lower portion of the cover toward the base until the cover release tabs "pop" as they lock in place.

#### To release cover when mounted:

To release the reader cover from the base when the reader is mounted, use the Cover Release Tool. See figure 4.

- 1 Insert the tool at the lower end of the reader in the thin opening between the wall and the readers' base.
- 2 When the tool is inserted as far as it will go (about 1/4"), move it to the far right side of the slot.
- 3 Pull the tool firmly downward (about 1/16") until the right retaining tab releases slightly. Grasp the lower end of the reader cover. Apply gentle pressure, holding the cover away from the base.
- 4 Re-insert the tool and in a similar manner release the left retaining tab. As the second tab releases, the cover should "pop" loose at the lower end of the base. Pull the cover back about a 1/2" and lift up to separate the cover and base.

## Diagnostic Tests

- 1 The Model 584 Insertion Card Reader is factory calibrated and is not field serviceable.
- 2 Direct substitution with a known good reader is the best way to isolate the problem.
- 3 A "good" card (expected card format on the proper track) will cause the reader LED to "wink" dark for 0.1 second.
- 4 If not possible, or having done so and the problem still exists, measure the voltage drop at the reader between the RED (Positive) and the BLACK (Common) wire with the reader connected to the host. It should measure between 4.75 and 5.25 VDC. Low voltage is a common source of problems.
- 5 Verify that the card used to test is a known good card, and is authorized in host memory. Verify the reader options are set correctly for that particular host, and the proper "Comparison Number" or site code has been recorded in host memory.
- 6 Verify the wiring, continuity, and connections between reader and host. If possible, switch the reader input wiring at the host to another known good input terminal group.
- 7 If the problem still cannot be resolved, contact Dorado by HID Technical Support, (949) 598-1600.