

HEAD REPAIR KIT SERIES 600/700



9292 Jeronimo Road
Irvine, CA 92618-1905
Phone : +1 (949) 598-1600
Fax : +1 (949) 598-1619

- 3116-0312 Head Assembly Kit
- 3116-0316 Ceramic Head Assy Kit

Head kit consists of:

- 1- Read Head Assembly
- 1- Instructions 2280-3921

Attaching and Releasing Reader Cover

CAUTION

Before touching any internal reader parts, touch a grounded surface to discharge static electricity from your body.

Releasing Reader from Base Plate

1. To release the reader assembly from the reader base plate, insert the latch release tool into the reader assembly release slot, *making sure the tip of the tool rides on top of the latch*. When fully inserted, the tip of the tool will depress the latch sufficiently to clear the release stop. FIG 1

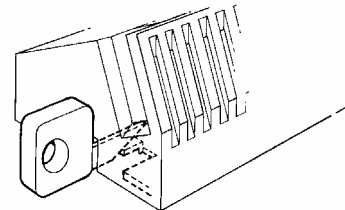

Figure 1

2. While holding the release tool in this position, slide the reader assembly forward (approximately 1/4") and lift the reader off its base.
3. Unplug cable connector assembly from the back of the reader.

P/N: 2280-3921
REV 5
(NA3921)
ECO# 011503-1

Installation Instructions

1. Release the reader assembly from its base plate.
2. Remove the circuit board from the housing by carefully inserting a small screwdriver between the reader housing and the circuit board at the mid-point and gently prying up. Fig.2

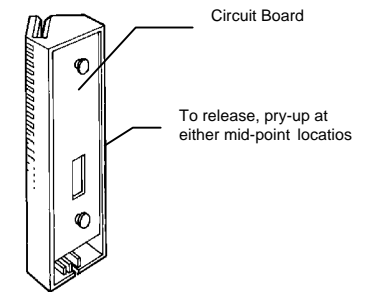

Figure 2

3. Unplug the reader head assembly connector from the circuit board. On models without this feature cut the read wires leaving enough on the circuit board for pigtail soldering.
4. Before removing the old read head assembly from the reader housing, note the position of the read head assembly using the wire connector pins on the back of the head assembly as your reference. *The new read head assembly must be installed in an identical manner to prevent changing the read head track position.* (i.e. track I or II)
5. Install the new read head assembly using long nose pliers.
6. Plug in the read head assembly connector to J2 of the circuit board. NOTE: on models without the J2 pins, cut off read head assembly connector and solder remaining ends of the white wire to the pigtail on the circuit board. Check for solder bridges.
7. Align the LED of the circuit board with the LED hole of the reader housing then snap in place.
NOTE: *Check that read head assembly wires are not tangled with any components that may restrict read head movement.*
8. Attach the reader assembly to its base plate.

Attaching Reader to Base Plate

1. Plug the cable connector assembly into the back of the reader (the plug is designed to fit only one way).
2. Align the two protruding retainer pins in the underside of the reader assembly with the corresponding holes in the reader base plate. FIG 3

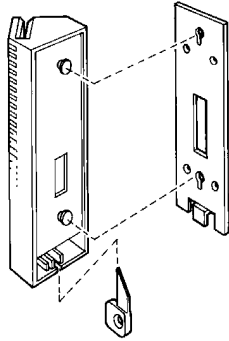
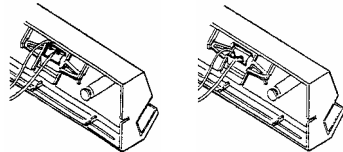

Figure 3

3. Fully insert these pins into base plate holes and gently slide the reader assembly in the direction of the base plate latch (approximately 1/4") until the latch locks against the latch release stop.

Head Track Adjustment

The reader head track location may be changed in the field by snapping out the head/gimbal assembly, rotating the assembly 180 degrees, and re-installing the assembly in the reader case.



Track I

Head wires toward
Face of reader

Track II

Head wires away
From face of reader

Installation Instructions For 700 Series

- 1) Release the reader assembly from its base in the normal manner. See instructions on back of page.
- 2) Remove 4 mounting screws off back plate.
- 3) Unplug connector of head assembly from PCB assembly.
- 4) Remove the 2 mounting screws from the Pass-Through housing.
- 5) Before removing the old read head assembly from the reader housing, note the position of the read head assembly as your reference. The new read head assembly **must** be installed in an identical manner to prevent changing the read head track position. (i.e. Track1 or 2) FIG. A
- 6) Install the new read head assembly a long nose pliers.
- 7) Align holes of mylar to Pass-Through housing with connector wire going through middle hole.
- 8) Position Pass-Through housing to reader base. See FIG. B
- 9) Plug connector to J2 of PCB assembly.
- 10) Secure Pass-Through housing using 2 #6 bolts.
- 11) Position back plate to reader base as shown and secure with 4 #4x1/2" screws.
- 12) Install the reader assembly to its' base mounting plate.

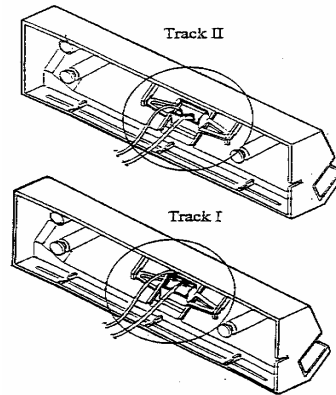

Head Head Track Position
FIG A

