

**HID Corporation**  
**Installation Instructions - HSM - HID Switch Monitor**  
**Model # 6020**

**System Overview**

The MultiProx reader subsystem is designed to retrofit existing Schlage/Westinghouse systems that use 2814/2815 type sensors ,708/808 type controllers, and SE774 MSM(s). The MultiProx Reader subsystem reads Schlage/Westinghouse Command Keys (1030, 1040 or 1050) along with HID ProxCard II Cards and interfaces to all host systems that have standard Wiegand electrical interfaces. The MultiProx reader subsystem uses the existing coax cable and provides monitoring input points and associated outputs that are the functional equivalent of the Schlage/Westinghouse MSM module. The MultiProx Reader subsystem directly replaces the existing Schlage/Westinghouse components without major modifications to the existing mounting hardware. This includes the mounting holes and cable locations.

MultiProx Reader Subsystem Layout Diagram

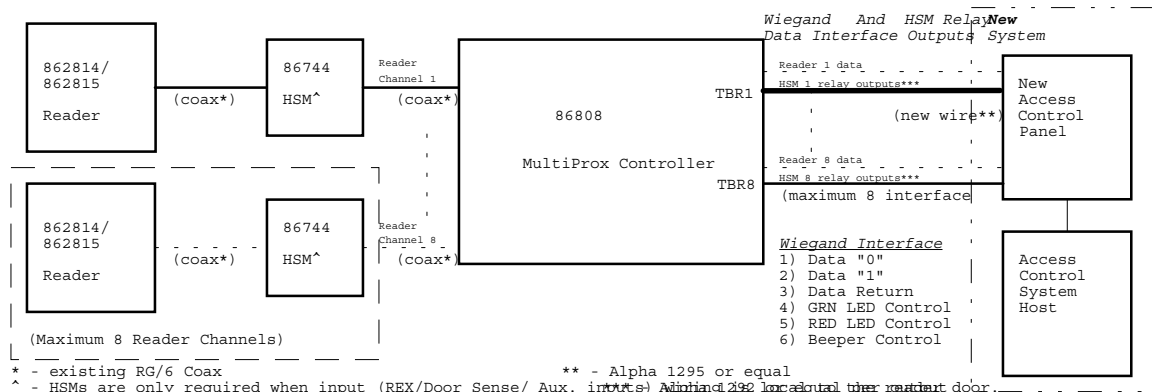

**Operation**

The **HSM** (HID Switch Monitor) is the direct replacement of the Schlage/Westinghouse MSM that is used in the MultiProx reader subsystem. The HSM interfaces from one to four sets of contacts that are reported to an access control /monitoring system by relay contacts on the MultiProx Controller. The relay outputs mimic the switch inputs monitored by the HSM. Replacement of the Schlage/Westinghouse MSM consists of removing and replacing the existing MSM circuit board with the HSM. The HSM is only required when the MSM is installed remotely from the Schlage/Westinghouse 708 or 808 panel. If the MSM is located next to or near the 708/808 panel and the wiring for the switches are accessible, the existing wiring maybe used to wire directly into the Access Control Panel. The typical applications for the contacts are door switch, request to exit (REX), infrared (IR) motion detectors, glass break detectors, or other types of monitoring devices.

The relays on the controller are energized in the normal state. If the controller loses power, the relays will de-energize and change to the “alarm” state. The relay outputs are grouped by channel and have specific connector assignments.

**Parts List**

- |  |   |                  |
|--|---|------------------|
| 1) HSM                                   | p/n 6020-301-01                         | qty 1 (included) |
| 2) Installation Sheet                    | p/n 6020-900                            | qty 1 (included) |
| 3) Relay Modules                         | p/n 33-0001-01                          | qty 4 (included) |
| 4) Terminal Connectors                   | p/n 46-0007-02                          | qty 1 (included) |
| 5) Shunt/Jumper                          | p/n 146-0002-00                         | qty 4 (included) |
| 6) Contact Cable, 2 conductor, 22 AWG    | as required/installed per contact       |                  |
| 7) Coax Cable RG/6 or SE 9284 equivalent | as required/installed (1000 ft maximum) |                  |
| 8) Power Requirements (14 - 28.5 VDC )   | provided via Coax Cable from Controller |                  |

**Installation Procedure For Retrofitting existing MSM**

1. Locate the existing MSM.
2. Remove the Coax cable from the MSM. Dismount the MSM.
3. Remove the MSM printed circuit board by loosening the nuts on the F-connectors, end screws on the terminal block and mounting screws internal to the MSM housing.
4. Pry the MSM printed circuit board from the housing. Pigtails on the terminal block are inserted into sockets on the printed circuit card. Use caution not to break the pigtails on the terminal block.

5. Place the HSM into the housing by placing the pigtails of the terminal block into the respective socket of the HSM printed circuit board. The F-connectors will fit directly into the existing holes.
6. Replace the internal mounting screws, the end screws on the terminal block and the F-connector nuts.
7. Attach the Coax cables (hand tight) to either connection. The connections are not device specific.
8. The connections to the switches are not affected and do not require rewiring or reconfiguration.

**At the Controller**

9. Determine which channel the Reader and the HSM are to be connected. Install the relays on the controller in the associated sockets for the channel. The sockets and terminal connections are marked for the respective channel. For example, for channel 1, relays are marked RLY1A, RLY1B, RLY1C and RLY1D and the terminal is marked TBR1. For channel 2, relays are marked RLY2A, RLY2B, RLY2C and RLY2D and the terminal is marked TBR2.
10. Connect the inputs of the Access Control Panel to the terminal connector for the relay outputs. Place the connector on the terminal that is marked TBR1 through TBR8 for the respective channel. Consult the Access Control Panel installation guidelines for the correct contact configuration.
11. Configure the relay contact configuration for either normally open or normally closed contacts using the shunt/jumper provided. The jumpers are marked J1A through J8D for the respective channel and relay. The relay contact configuration refers to the "alarm" state of the monitored switch. Place the shunts/jumpers across the jumper pins **NC for closed contacts in the alarm condition** or **NO for open contacts in the alarm condition**. The jumper setting should be set so the relay contacts follow the switch contacts. The relays on the controller are energized in the normal/non alarm state.
12. Place switch 8 of SW2 to the "on" position (on the controller). After all connections are checked, apply power and verify function.

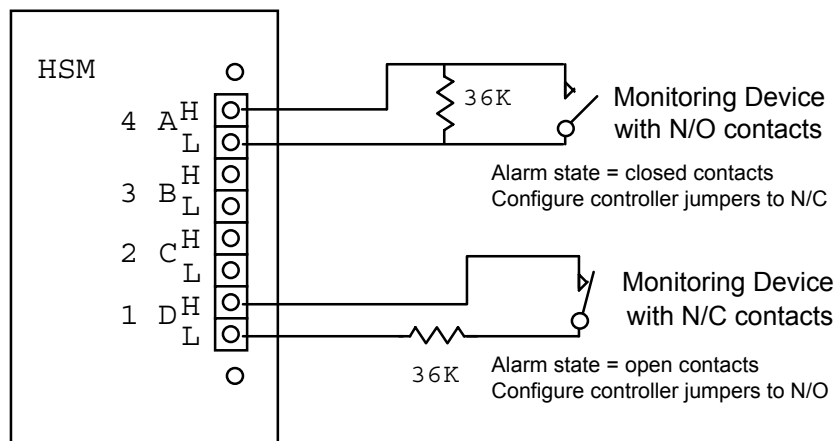
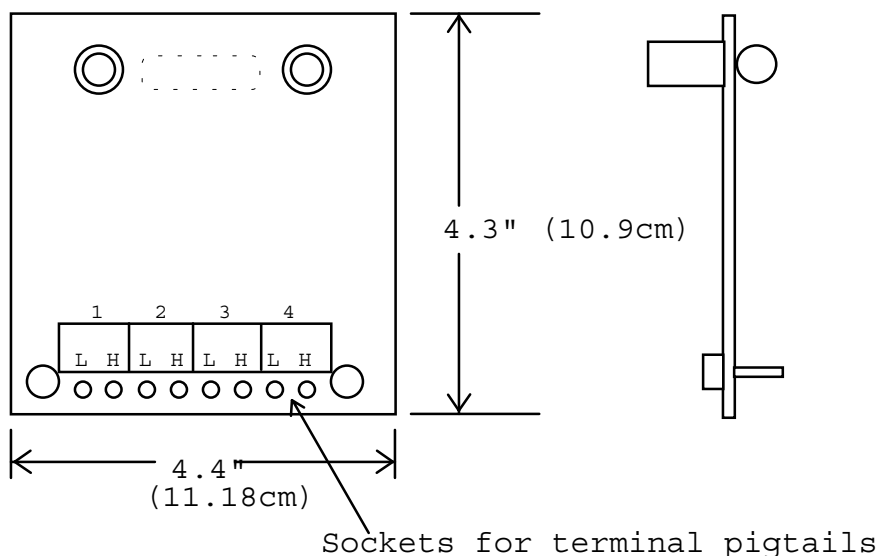

**Controller Connectors  
TBR1-TBR8**

- pin 1 - relay output (rly A) for input 4
- pin 2 - common output (A) for input 4
- pin 3 - relay output (rly B) for input 3
- pin 4 - common output (B) for input 3
- pin 5 - relay output (rly C) for input 2
- pin 6 - common output (C) for input 2
- pin 7 - relay output (rly D) for input 1
- pin 8 - common output (D) for input 1

**Note: The above are recommended installation procedures. All Local, State, and National Electrical Codes have precedence**

HID

14311 Chambers Road Tustin, CA 92680 USA TEL (714) 734-3600 (800) 237-7769 FAX (714) 669-5623  
6020-900-01 rev A November 7, 1995