

# **HID® FARGO® DTC™ii and DTCii Plus**

## Recommended Maintenance

PLT-06335, A.0  
February 2022



## Copyright

© 2022 HID Global Corporation/ASSA ABLOY AB. All rights reserved.

This document may not be reproduced, disseminated, or republished in any form without the prior written permission of HID Global Corporation.

## Trademarks

HID GLOBAL, HID, the HID Brick logo, the Chain Design, FARGO, and DTC are trademarks or registered trademarks of HID Global, ASSA ABLOY AB, or its affiliate(s) in the US and other countries and may not be used without permission. All other trademarks, service marks, and product or service names are trademarks or registered trademarks of their respective owners.

## Contacts

For technical support, please visit: <https://support.hidglobal.com>.

## What's new

Date	Description	Revision
February 2022	Initial release.	A.0

A complete list of revisions is available in [Revision history](#).

---

<b>Introduction</b> .....	<b>4</b>
1.1 Daily maintenance .....	5
1.2 Preventive maintenance .....	5
<b>Cleaning routines</b> .....	<b>6</b>
2.1 Adhesive cleaning card routine .....	7
2.2 IPA cleaning card routine .....	8
2.3 Print head cleaning routine .....	9

# Section **01**

Introduction

## 1.1 Daily maintenance

Perform these steps daily:

- Remove and discard any rejected cards.
- Clean the card transport path as needed. Once every 250 cards at minimum depending on environment, card quality, and usage rate as noted in **Preventive maintenance**.

**Note:** For maximum output in high throughput situations, daily card path cleaning is recommended.

- Wipe exterior of printer with dry microfiber cloth to remove dust and debris from surfaces, including card input hopper covers.

## 1.2 Preventive maintenance

It's recommended to perform inspection and preventative maintenance regularly depending on environment and usage. The following tasks are for ideal conditions, with a clean and dry air office environment.

- Each print ribbon includes a new cleaning roller. When you replace the print ribbon, replace the supplied cleaning roller.
- Clean the printer after every 250 cards printed or one month, whichever comes first.

This involves cleaning parts, such as the card path, card path rollers, and print head using the cleaning kits available for sale. Please ensure to use both the adhesive card and IPA card when cleaning the card path and rollers.

# Section **02**

Cleaning routines

## 2.1 Adhesive cleaning card routine

Video link: <https://player.vimeo.com/video/679193087>

The following diagram shows the location where the cleaning card is inserted into the printer.

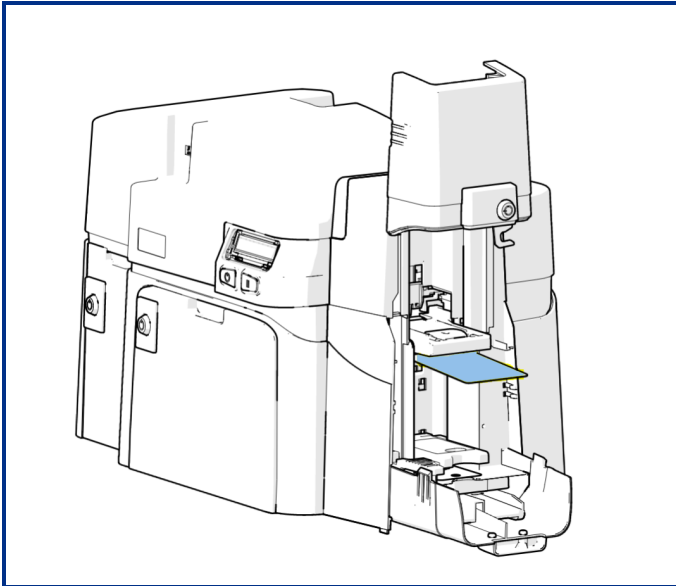

1. Remove all cards from the card hopper.
2. Take out the ribbon cartridge and set it aside. Close the door.
3. Remove the paper backing from both sides of the cleaning card.  
**Note:** Do not remove small liner strip, if a magnetic encoding module is installed in your printer.
4. Insert the cleaning card into the in-feed rollers of the card hopper.
5. Navigate through the onscreen menu to the Toolbox and select **Clean Printer**.
6. Guide the cleaning card into the printer, if necessary.
7. When the cleaning routine is completed, the cleaning card exits the printer.
8. Discard the cleaning card as it is a one-time use item.
9. Re-install the ribbon.
10. Re-install all cards that were removed.

## 2.2 IPA cleaning card routine

Video link: <https://player.vimeo.com/video/679193300>

The following diagram shows the location where the IPA cleaning card is inserted into the printer.

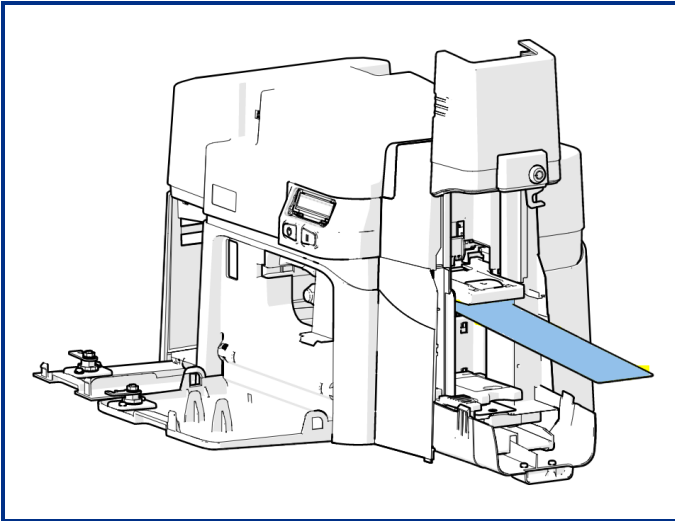

1. Remove the ribbon cartridge from printer, set it aside, and leave front door open.
2. Open the reject hopper door.
3. Remove all cards from input hopper and leave open.
4. If equipped with dual input hopper, lower the bottom hopper tray to the bottom position.
5. Remove the long IPA card from its packaging and insert it into the printer card path through the bottom hopper. Guide the cleaning card into the printer, if necessary. Push the card in until the rollers begin to move it on its own.
6. Use the onscreen forward and backward buttons to move the card through the printer.
7. Once all the way in, hold the edge of the card in a stationary position. Continue pressing the forward and backward buttons to allow the rollers to drive and slip against the card.

**Note:** This step is very important and has the greatest effect on cleaning.

8. Run the card backwards until you can pull it fully out of the printer.
9. Discard the card, as it is a one-time use item.
10. Close the reject hopper.
11. Re-install the ribbon cartridge and close the door.
12. Re-install the cards into the input hopper.



## 2.3 Print head cleaning routine

Video link: <https://player.vimeo.com/video/679193550>

The following diagram shows the location of the print head.

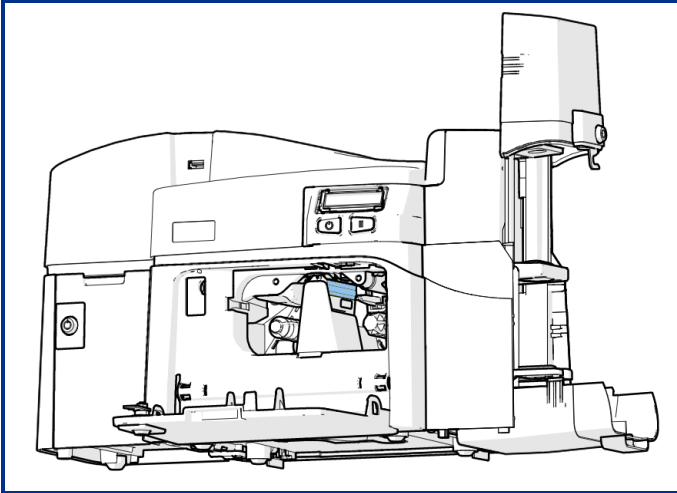

1. With the printer on, open the front door and remove the ribbon cartridge and set it aside.
2. Power off the printer and remove the power cord.
3. Remove the print head cleaning swab from the packaging.
4. Rub the swab back and forth over the print head terminal.  
Repeat this a few times to wipe any debris from the print head.
5. Discard the swab as it is a one-time use item.
6. Close the front door.
7. Plug the power cord in and turn the printer on.
8. Re-install the ribbon into the printer.

## Revision history

Date	Description	Revision
February 2022	Initial release.	A.0



hidglobal.com

For technical support, please visit: <https://support.hidglobal.com>

© 2022 HID Global Corporation/ASSA ABLOY AB.

All rights reserved.

PLT-06335, Rev. A.0

Part of ASSA ABLOY